

# SCOTSMAN

MODULAR ICE STORAGE BINS

## HTB250, HTB350

HTB250



### VOLUME STORAGE – AMPLE ICE RESERVE

- HTB250 holds up to 190 lbs. the HTB350 holds up to 270 lbs. per ARI standard 820-95.
- Low profile design allows for ice machine placement where ceilings are low.
- Ideal storage companions for Scotsman 30" CME models.

### QUALITY CONSTRUCTION

- Polyethylene exterior eliminates rust and corrosion.
- Impact resistant exterior prevents unsightly dents and chips.
- Attractive grey color blends well with all decors.

### WARRANTY PROTECTION *See Dealer for complete warranty details.*

- 5 years parts and labor on all components.
- Limited Lifetime Rust Free Parts Warranty On Food Zone.

HTB350

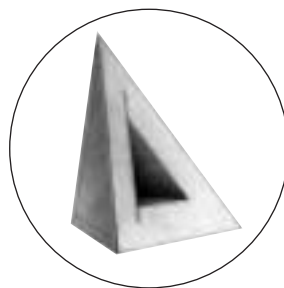

### POLYURETHANE INSULATION

Foam insulation is forced between the wall and liner under heat and pressure to form a perfect wall to wall bond, preserving ice supply for long periods.

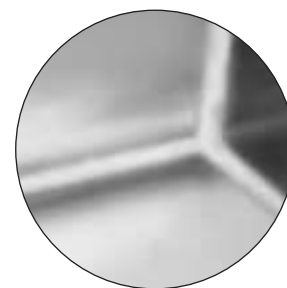

### BIN Interior

The polyethylene bin interior is sanitary and easy to clean. Resists scratches and scuffs from ice scoops.

Bin includes 6" black enamel legs w/ adjustable leveling.



*Scotsman is proud to announce that we are ISO-9001:2000 Certified*



# Bin Specifications

## HTB250

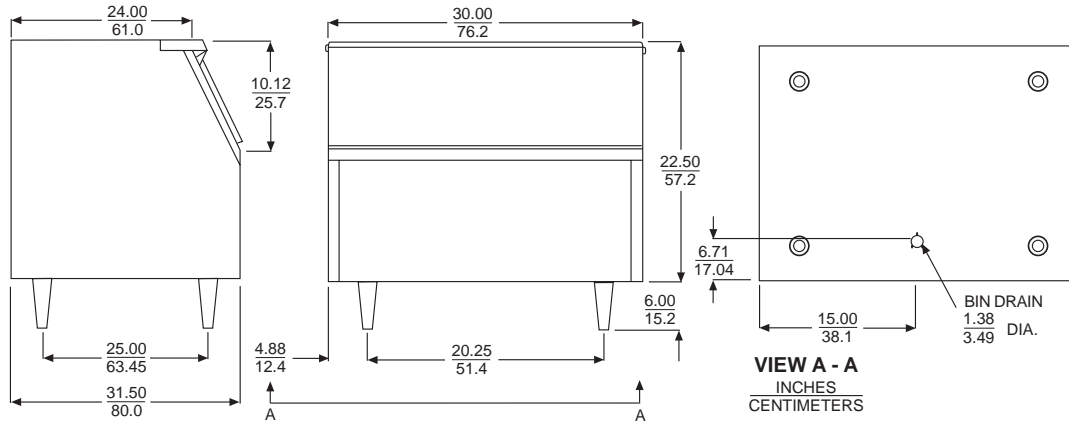

## HTB350

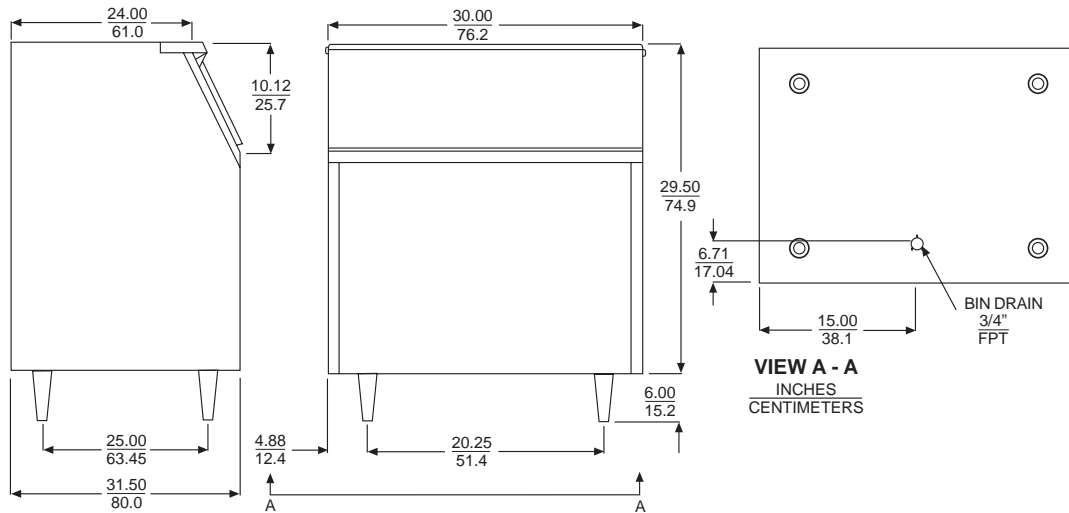

NOTE: Allow 6" minimum space at back for ice machine ventilation and utility connections.

SCOTSMAN MODULAR BINS			Certified & rated in accordance with ARI standard 820-95		
Model Number	Dimensions W"xD"xH"	ARI Bin Capacity lbs./kg.	Application Capacity lbs./kg.	Finish*	Ship Weight lbs./kg.
HTB250	30 x 31.5 x 22.5	190/86	250/113	HTB	80/36
HTB350	30 x 31.5 x 29.5	250/113	350/159	HTB	90/41

\* HTB is a low density polyethylene (cabinet and liner) with a grey color.

ARI storage capacity for bins is based on 80% of total volume in cubic feet x 30 lb./ft<sup>3</sup> average density of ice. Application capacity for bins is based on 90% of total volume in cubic feet x 34 lb./ft<sup>3</sup> average density of ice. NOTE: Add 6" height for legs.

Scotsman's ice machines and bins are not designed for outdoor installations. Scotsman remote condensers are designed for outdoor installations.

Machine requires voltage indicated on rating name plate. Failures caused by improper voltage are not considered factory defects. Extended periods of operation at temperatures exceeding limitations constitutes misuse under the terms of Scotsman Manufacturer's Limited Warranty, resulting in a loss of warranty coverage. Specifications and design are subject to change without notice.

Consult Your Local SCOTSMAN Representative At:

## ACCESSORIES

Model Number	Description	Ship. Wt. Application	lb./kg.
KBT20A	Bin Top	Use with MFE400, NME654, NME954, FME804, FME1204.	25/11
KBC20	Caster Kit	Raises bin 47/16". Not to be used X NME954, FME804, FME1204.	20/9
KLP7	Flanged-foot leg kit	6" black enamel legs with flanged feet.	5/2
KLP4	Heavy-duty leg kit	6" aluminum legs & bracket. Must be used when machines are stacked.	25/11
KHOLDER	Ice scoop holder	Fits all modular ice storage bins.	2/1

**YOU'LL VALUE THE DIFFERENCE.™**

775 Corporate Woods Parkway • Vernon Hills, IL 60061 • 1-800-SCOTSMAN • (847) 913-9844  
Visit our website at: [www.scotsman-ice.com](http://www.scotsman-ice.com) • E-mail: [customer.service@scotsman-ice.com](mailto:customer.service@scotsman-ice.com)